

# MEZANINA

cama alta 135  
lit haut 135  
cama alta 135



---

L U F E



**IMPORTANTE: LEA LAS INSTRUCCIONES DETENIDAMENTE Y CONSÉRVELAS PARA CONSULTAS POSTERIORES.**

- . ADVERTENCIA: Las camas altas y la cama superior de una litera, no son adecuadas para niños menores de seis años, debido al riesgo de lesiones por caída.
- . ADVERTENCIA: Las literas y las camas altas pueden presentar un riesgo grave de estrangulamiento si no se utilizan correctamente. No se debe sujetar o colgar en ninguna parte de la litera, ningún elemento que no esté diseñado para utilizarlo como la cama. Por ejemplo: (pero puede haber otros) cuerdas, cordeles, cordones, ganchos, correas y bolsas.
- . ADVERTENCIA: Los niños pueden quedar atrapados entre la cama y la pared. Para evitar el riesgo de lesiones graves, la distancia entre la barrera de seguridad superior y la pared, no debe ser superior a 75mm, o debe ser mayor de 230mm.
- . Es conveniente ajustar correctamente los elementos de fijación y comprobar que no se desajustan.
- . Se recomienda que la litera no se utilice si alguno de sus componentes estructurales está roto o falta.
- . Es necesario que la habitación esté ventilada para mantener una humedad baja e impedir la formación de moho en la cama y sus alrededores.
- . Es conveniente revisar periódicamente que todos los elementos de fijación están correctamente ajustados.
- . El grueso máximo del colchón superior es de 210mm.
- . Seguir siempre las instrucciones del fabricante.
- . Esta litera cumple los requisitos de seguridad según la norma UNE EN 747:2012-1+A1:2015.



**IMPORTANT: LISEZ ATTENTIVEMENT LES INSTRUCTIONS ET CONSERVEZ-LES POUR RÉFÉRENCE ULTÉRIEURE.**

- . AVERTISSEMENT: Les lits mezzanines et le lit superposé du haut ne conviennent pas aux enfants de moins de six ans, en raison de risque de blessures en cas de chute.
- . AVERTISSEMENT: Les lits superposés et les lits mezzanines peuvent présenter un risque sérieux d'étranglement s'ils ne sont pas utilisés correctement. Ne pas fixer ni accrocher sur aucune partie du lit, tout élément qui n'est pas conçu pour être utilisé comme lit. Par exemple: (mais il peut y en avoir d'autres) cordes, ficelles, cordons, crochets, sangles et sacs.
- . AVERTISSEMENT: Les enfants peuvent se retrouver coincés entre le lit et le mur. Pour éviter tout risque de blessure grave, la distance entre la barrière de sécurité supérieure et le mur ne doit pas dépasser 75mm ou doit être supérieure à 230mm.
- . Il convient d'ajuster correctement les éléments de fixation et de vérifier qu'ils ne sont pas déréglés.
- . Il est recommandé de ne pas utiliser le lit superposé si l'un de ses composants structurels est cassé ou manquant.
- . La pièce doit être ventilée pour maintenir un faible taux d'humidité et empêcher la formation de moisissures dans et autour du lit.
- . Il est conseillé de vérifier périodiquement que tous les éléments de fixation sont correctement serrés.
- . L'épaisseur maximale du matelas supérieur est de 210mm.
- . Suivez toujours les instructions du fabricant.
- . Cette couchette est conforme aux exigences de sécurité de la norme UNE EN 747:2012-1+A1:2015.



**IMPORTANTE: LEIA ATENTAMENTE AS INSTRUÇÕES E GUARDE-AS PARA REFERÊNCIA POSTERIOR.**

- . AVISO: As camas loft e o beliche superior não são adequados para crianças menores de seis anos, devido ao risco de lesões por quedas.
- . AVISO: Beliche e camas altas podem representar um sério risco de estrangulamento se não forem usados corretamente. Não prenda ou pendure em nenhuma parte do beliche, qualquer elemento que não seja projetado para ser usado como cama. Por exemplo: (mas pode haver outros) cordas, cordões, cordas, ganchos, alças e bolsas.
- . AVISO: As crianças podem ficar presas entre a cama e a parede. Para evitar o risco de ferimentos graves, a distância entre a barreira de segurança superior e a parede não deve exceder 75mm ou deve ser superior a 230mm.
- . É conveniente ajustar correctamente os elementos de fixação e verificar se não ficam desalinhados.
- . Recomenda-se que o beliche não seja utilizado se algum de seus componentes estruturais estiver quebrado ou em falta.
- . O quarto precisa ser ventilado para manter a humidade baixa e evitar a formação de mofo dentro e ao redor da cama.
- . É aconselhável verificar periodicamente se todos os elementos de fixação estão ajustados correctamente.
- . A espessura máxima do colchão superior é de 210mm.
- . Siga sempre as instruções do fabricante.
- . Este beliche atende aos requisitos de segurança de acordo com a norma UNE EN 747:2012-1+A1:2015.

Cama alta 135 (4/1)

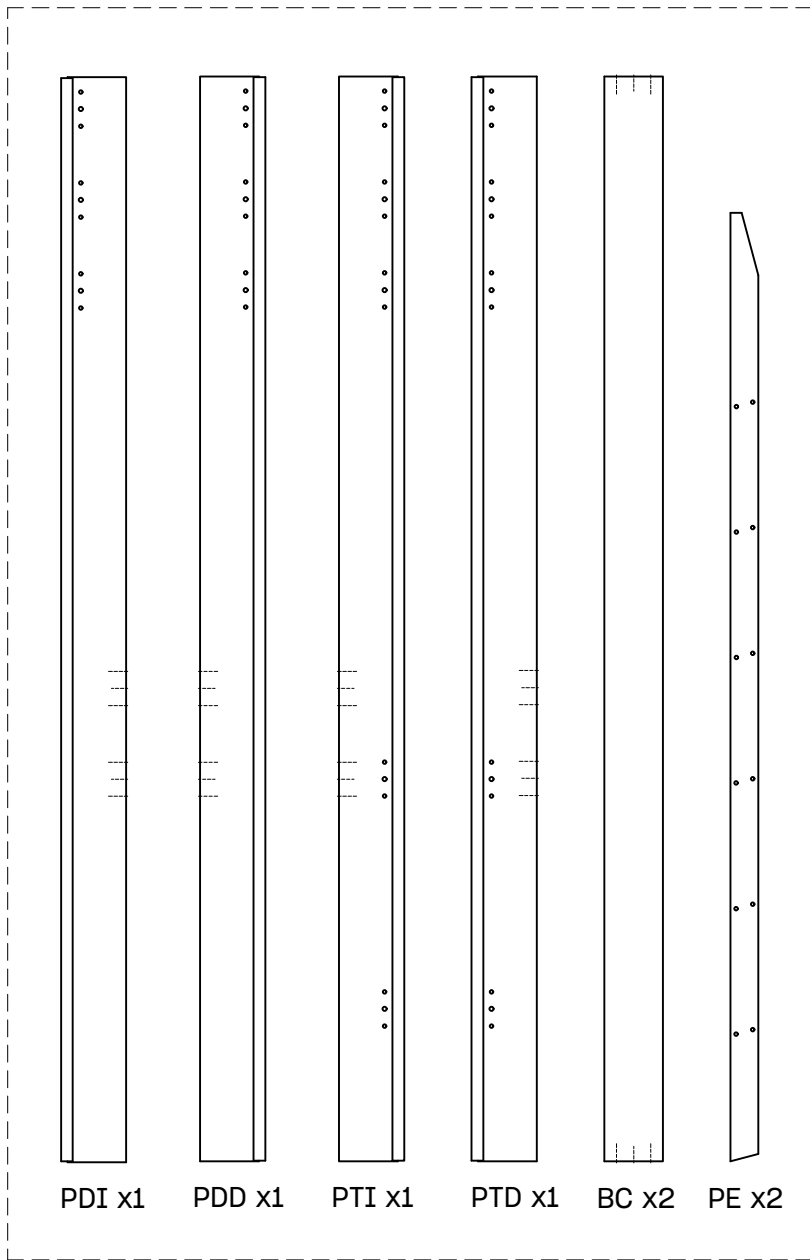

Cama alta (4/2)

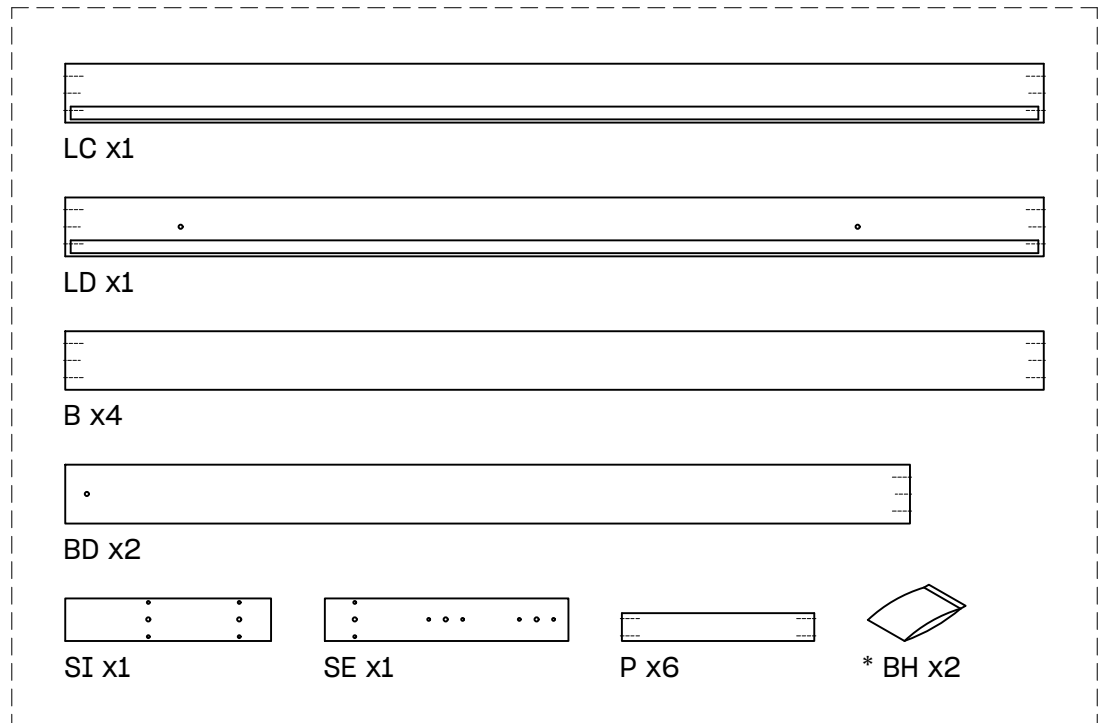

Cama alta 135 (4/3)

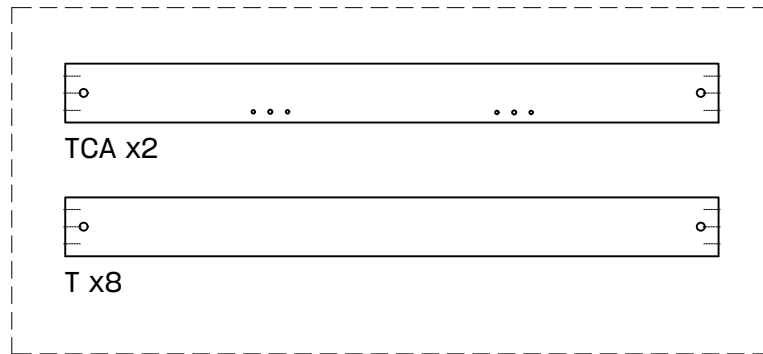

\* BH20-015

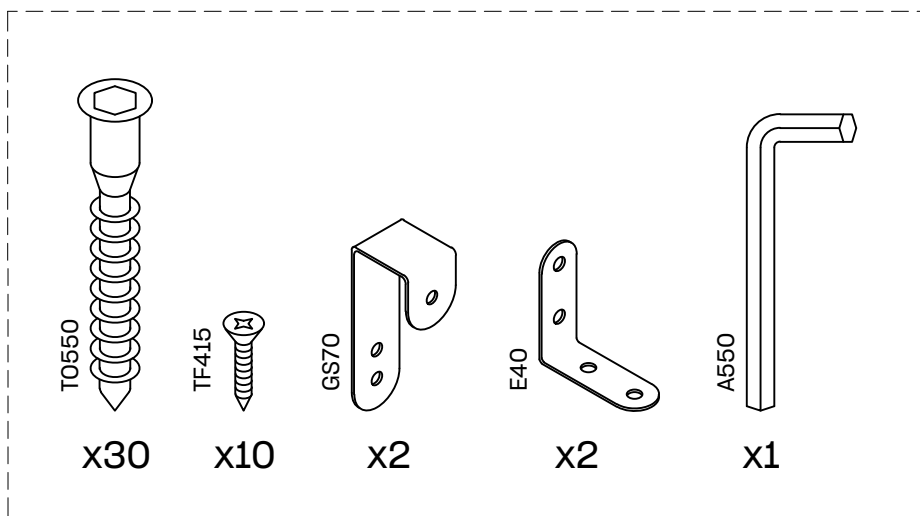

Cama alta 135 (4/4)

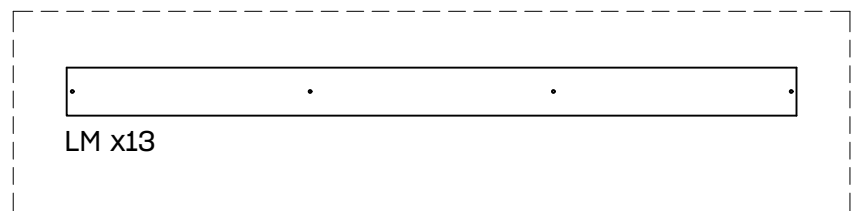

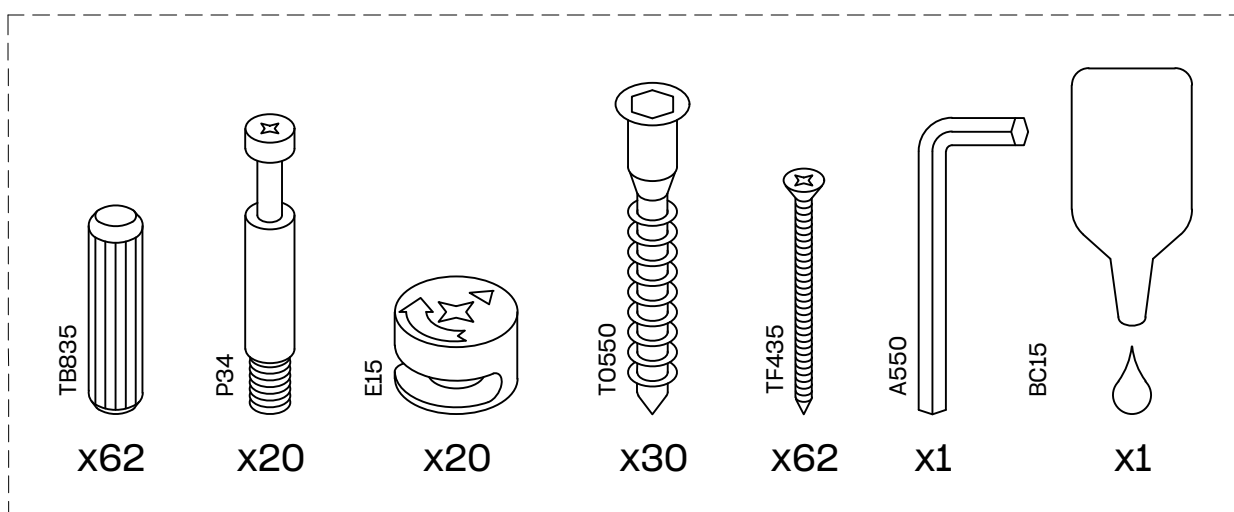

\* BH20-005

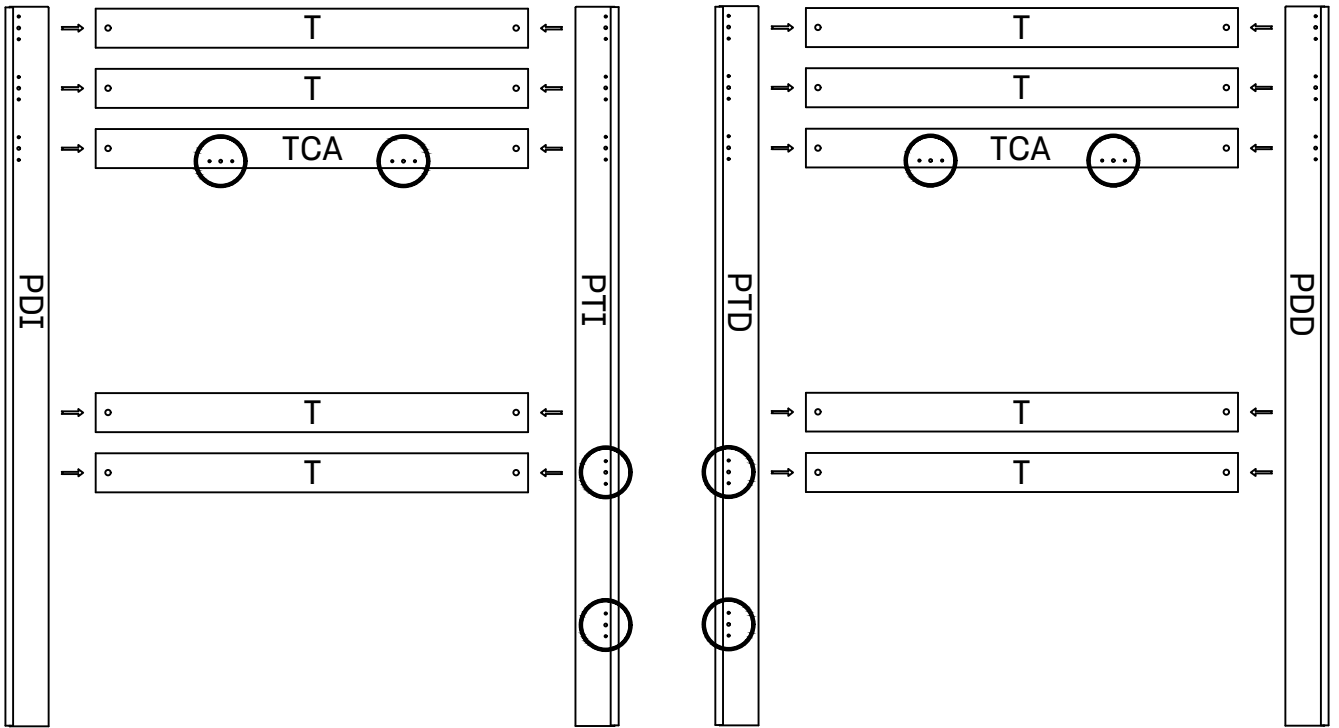

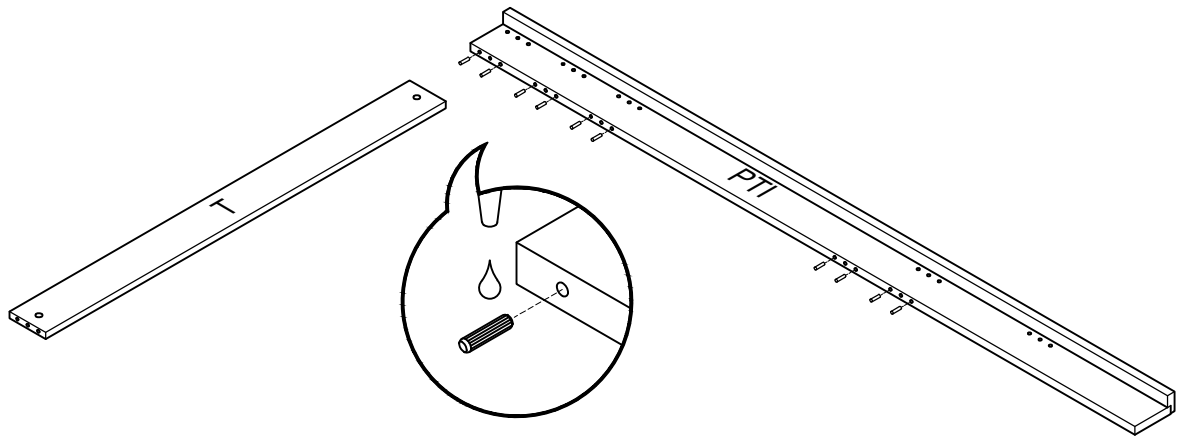
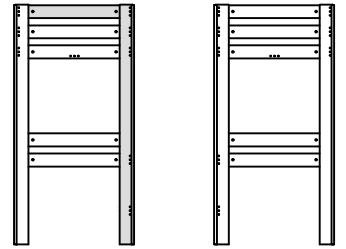

**1**  x 10  x 10



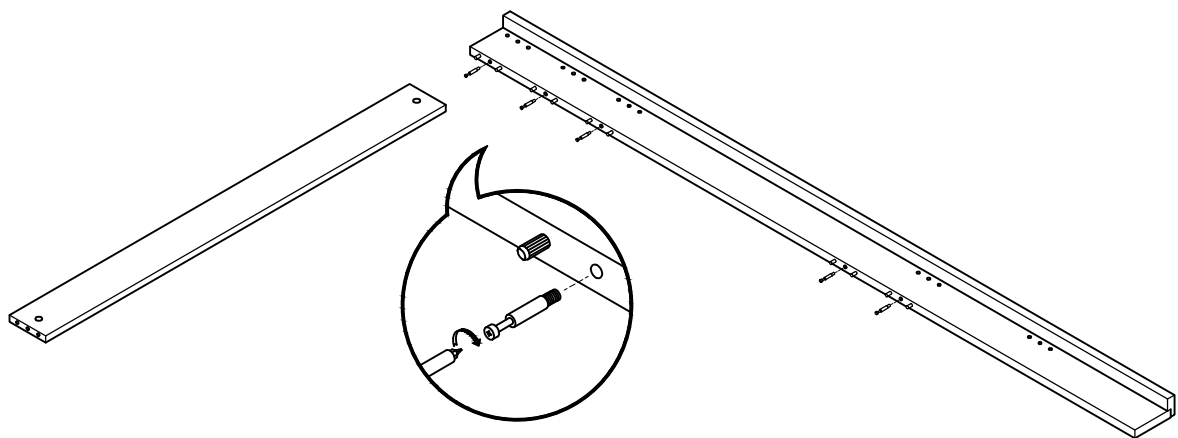
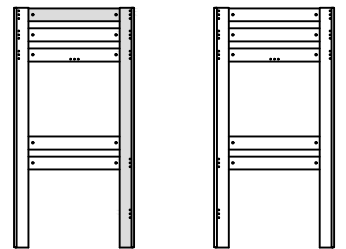

**2**  x 5

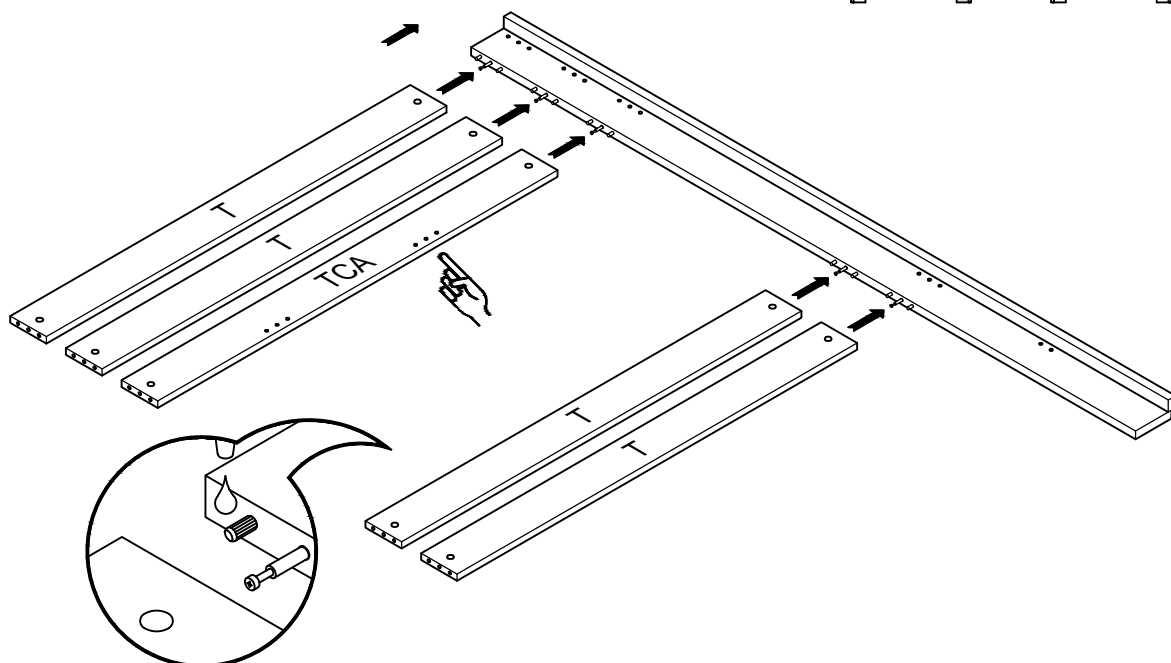
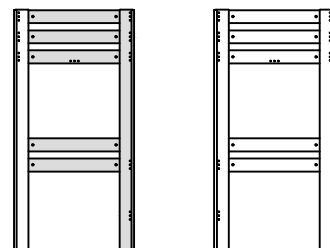

**L U F E**

3  x 10



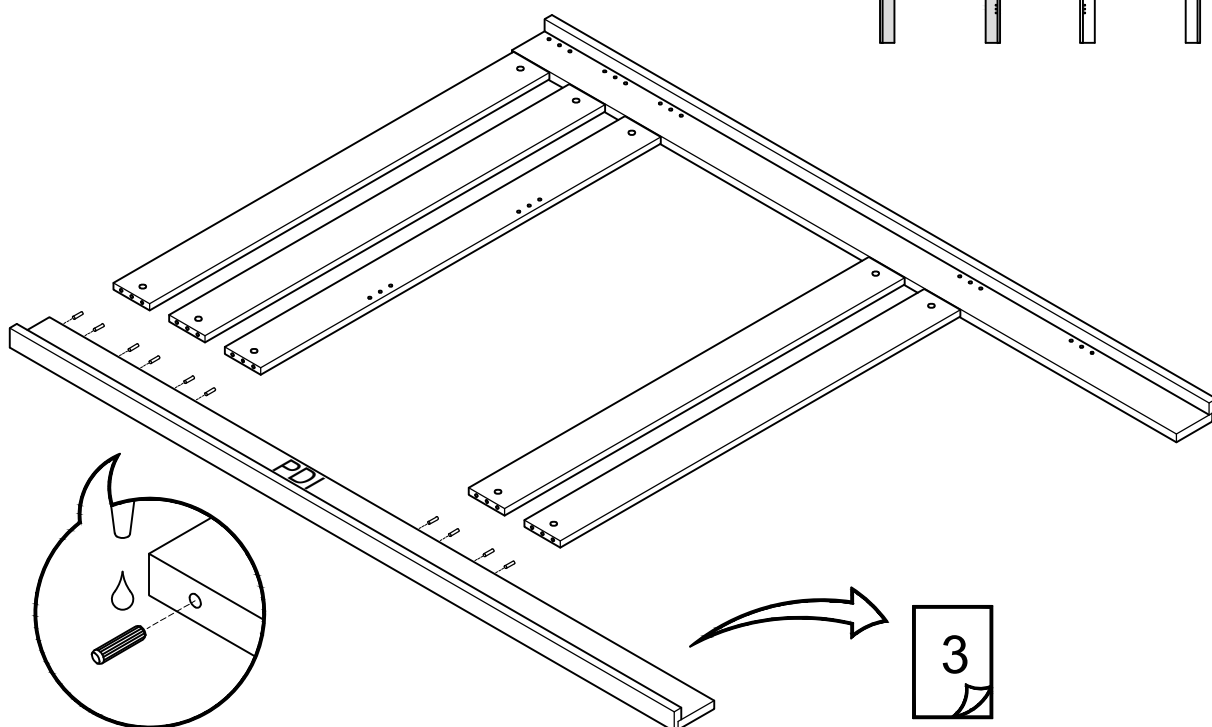
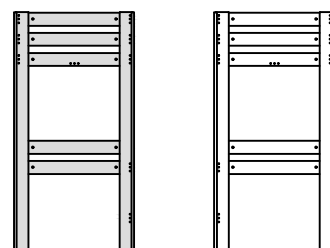

4  x 10

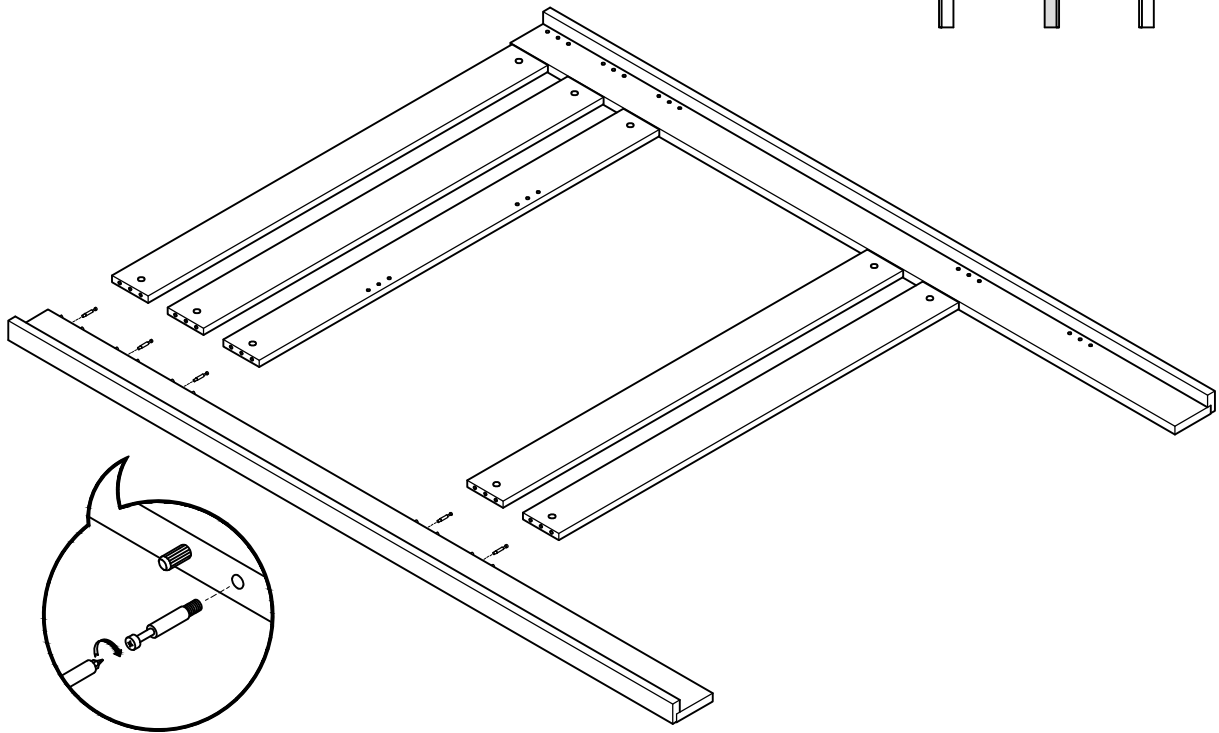
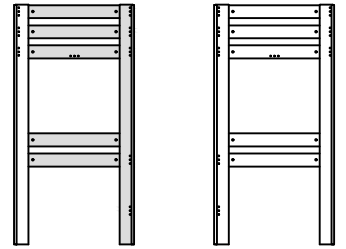

L U F E

5  x 5





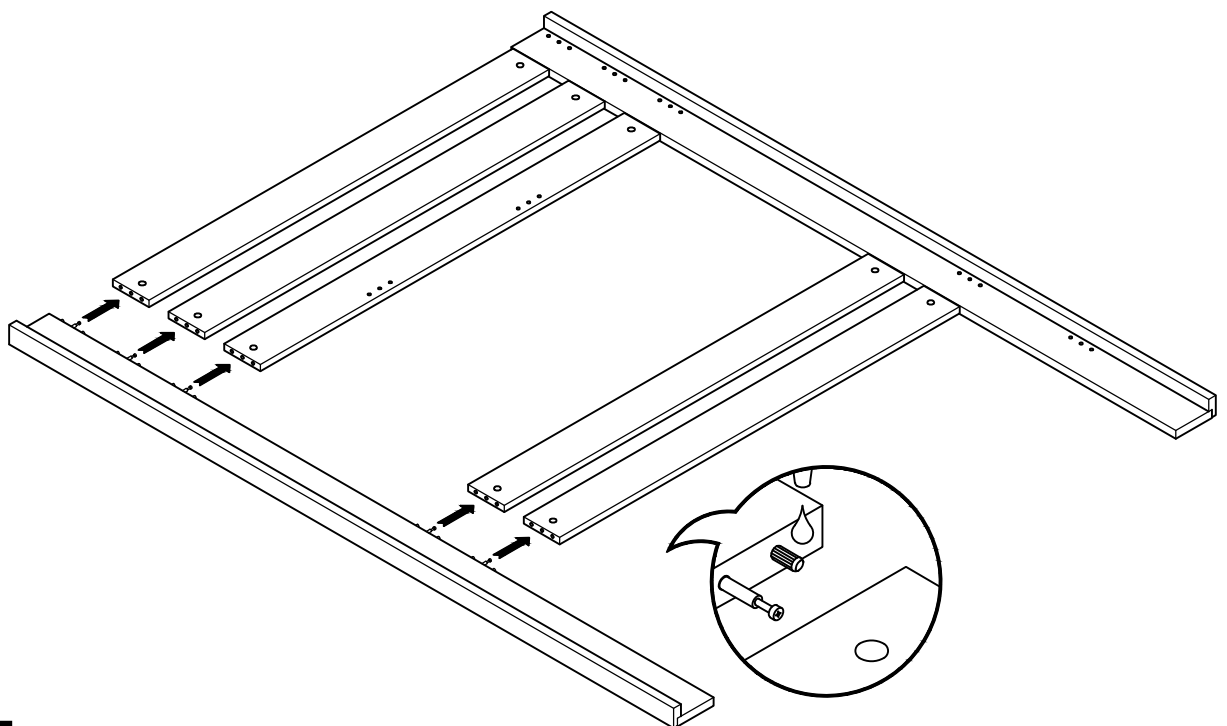
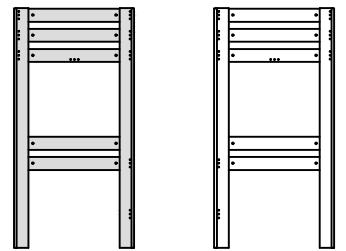

6  x 10

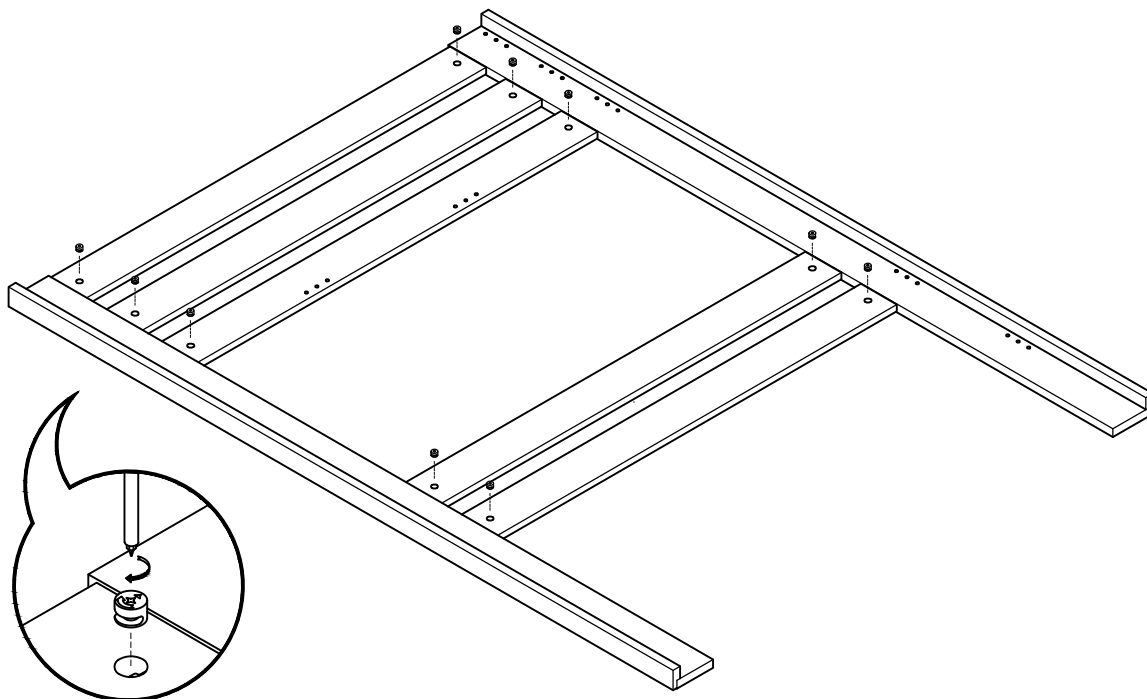
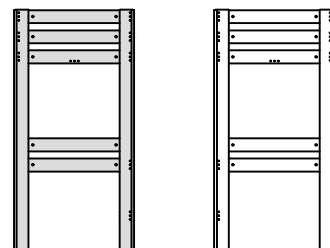

L U F E

7  x 10



8  x 20  x 10  x 10

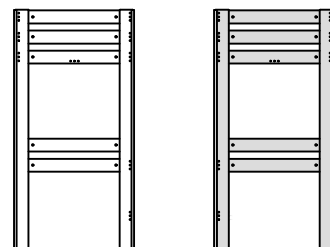

1

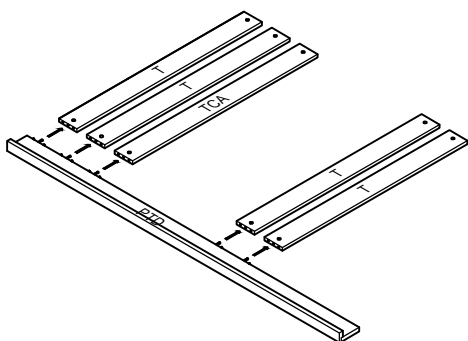

2

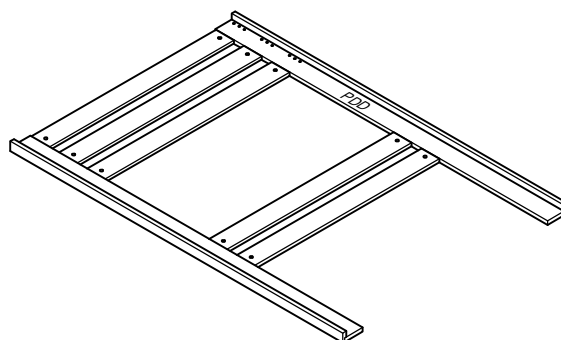

L U F E



9  x 8+8

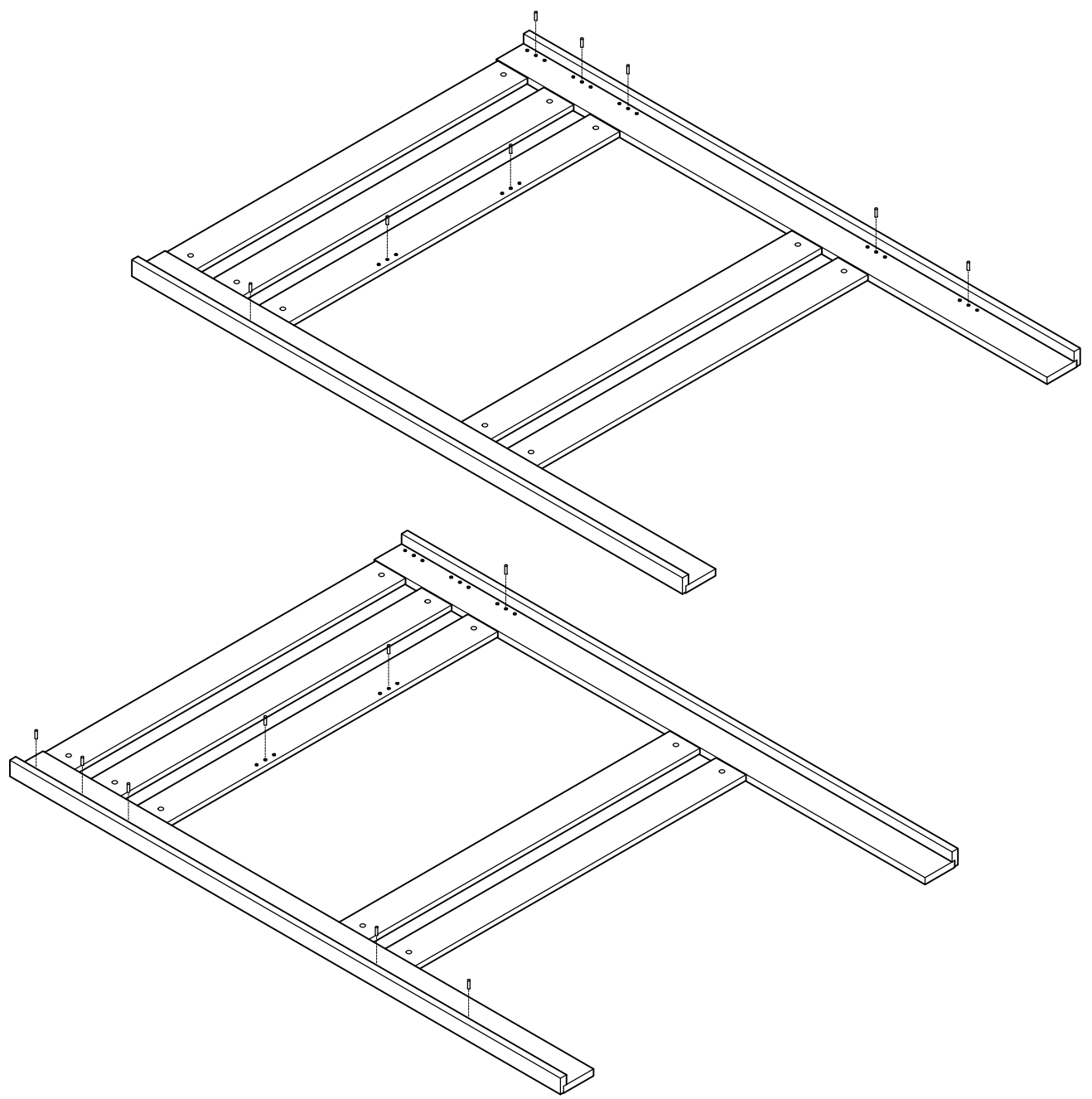
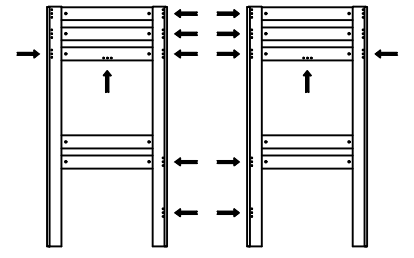

L U F E

10  x 8

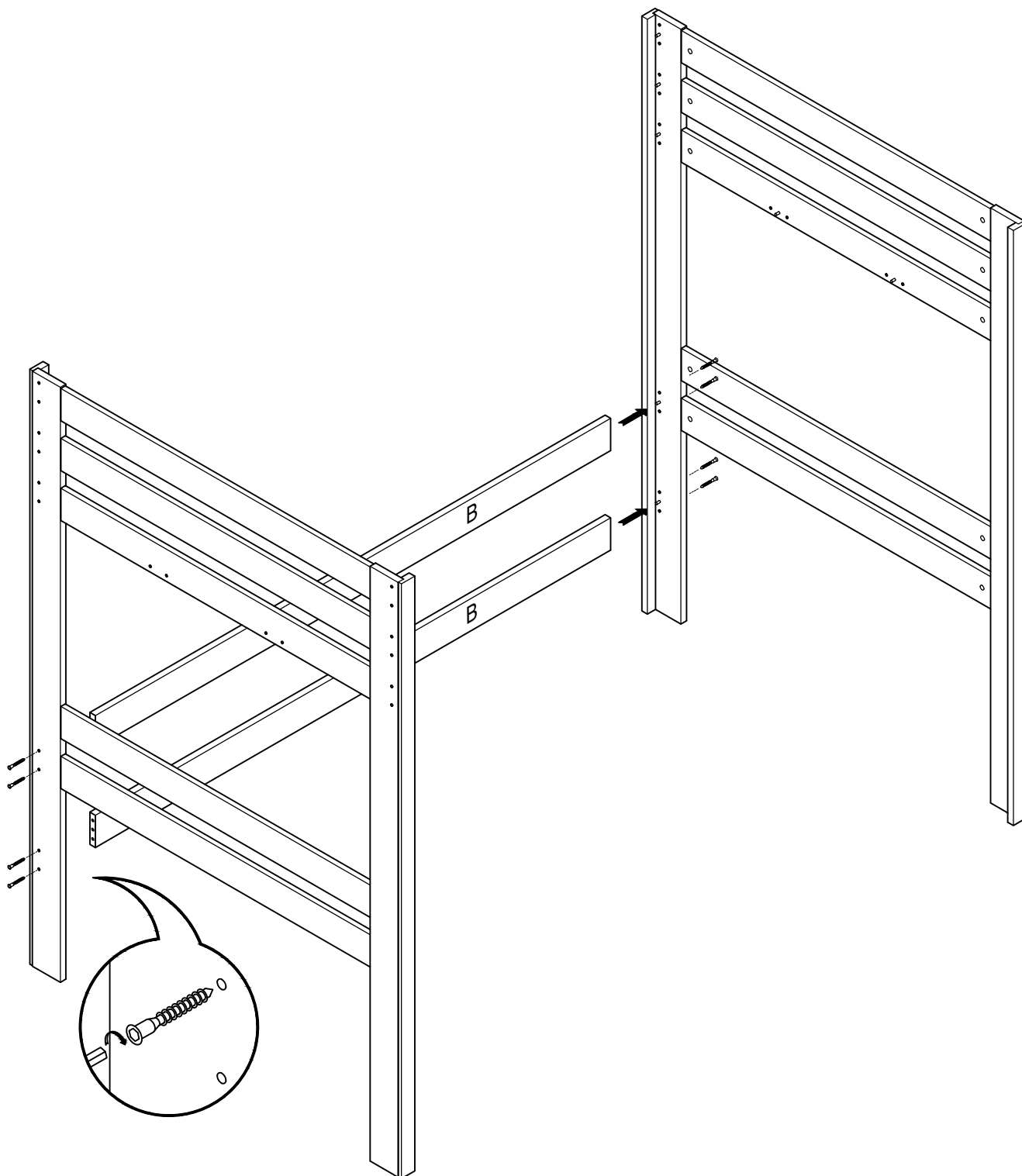
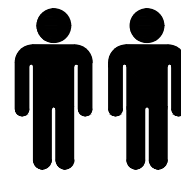

L U F E

11



x 20

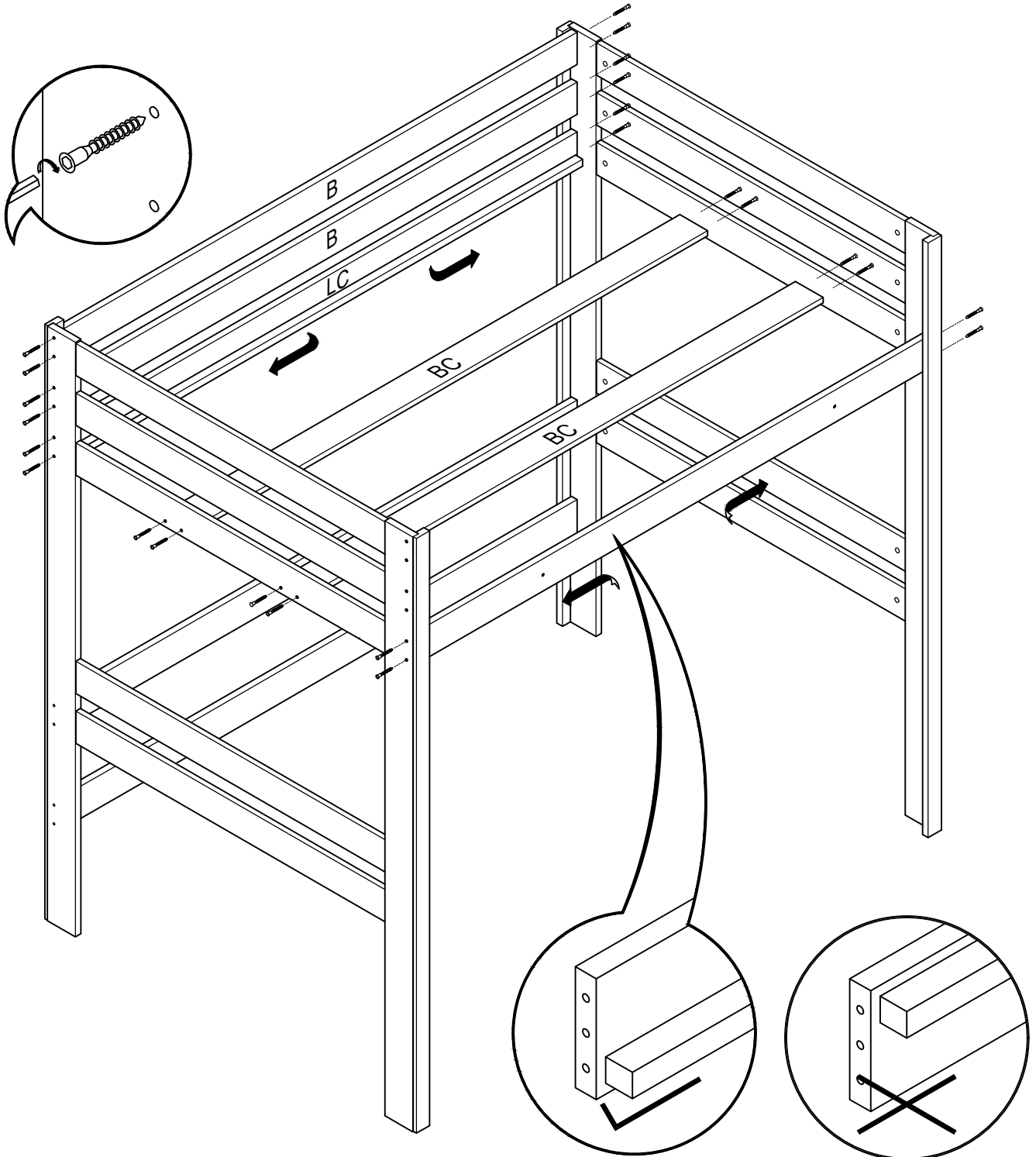
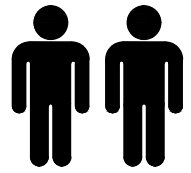

L U F E

12

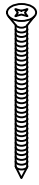

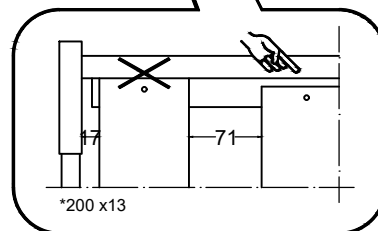
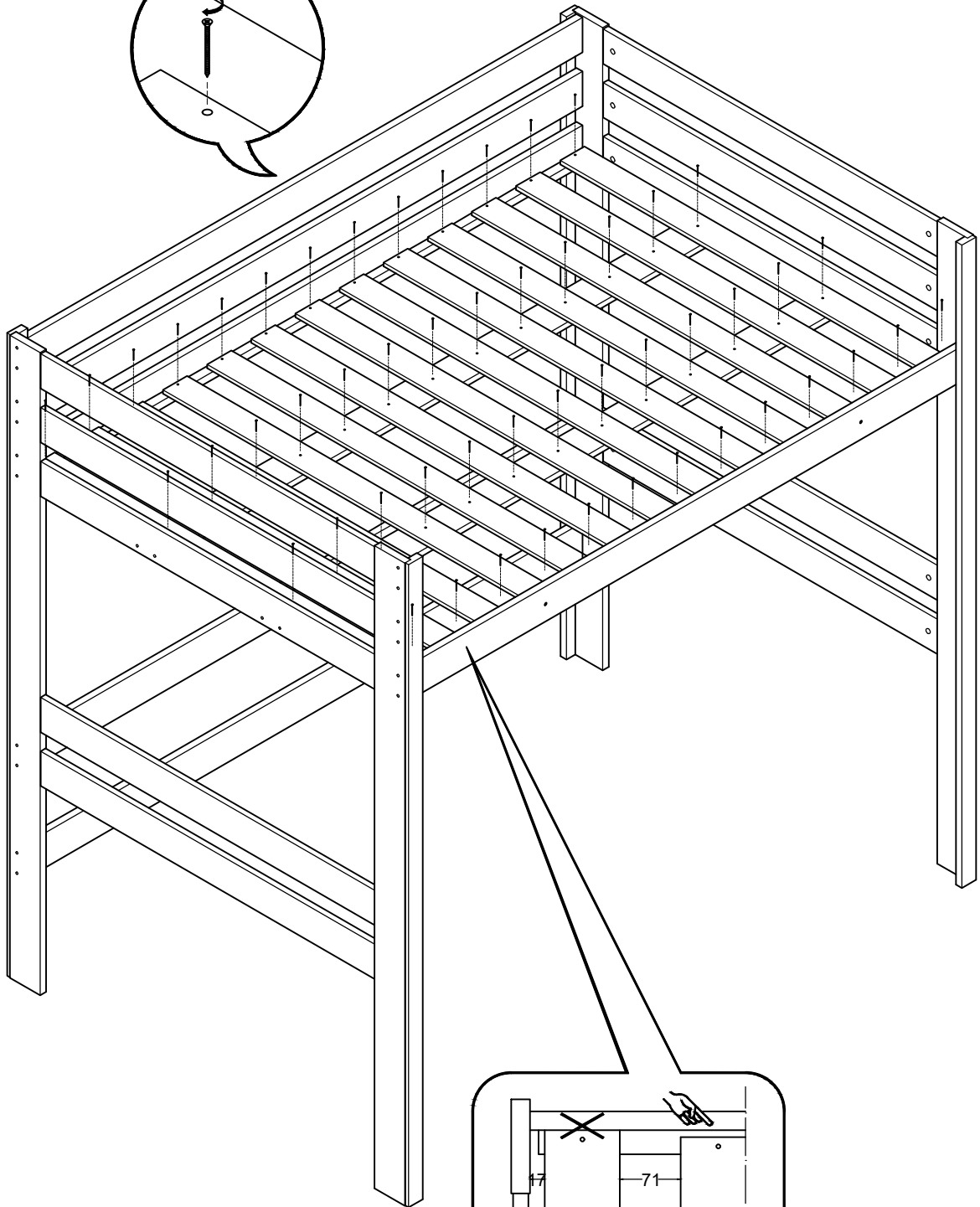
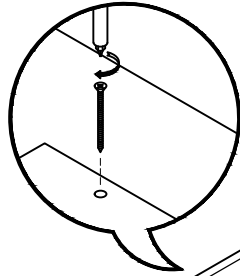
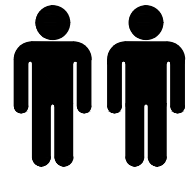

x 52

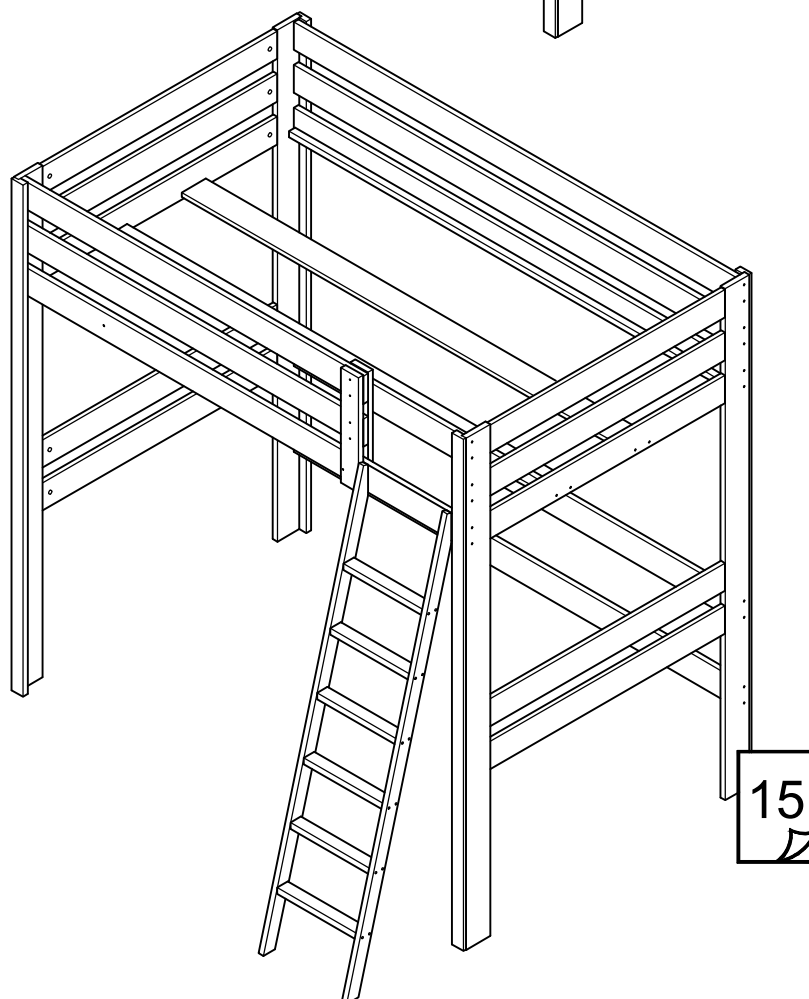
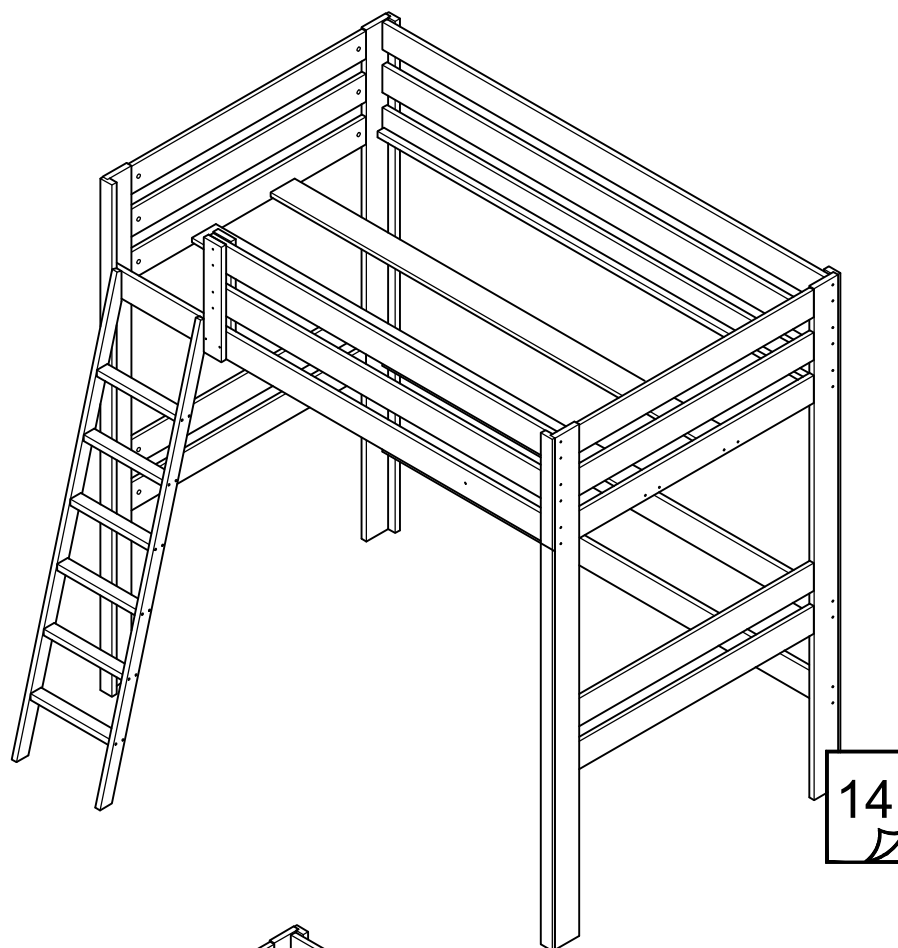

L U F E



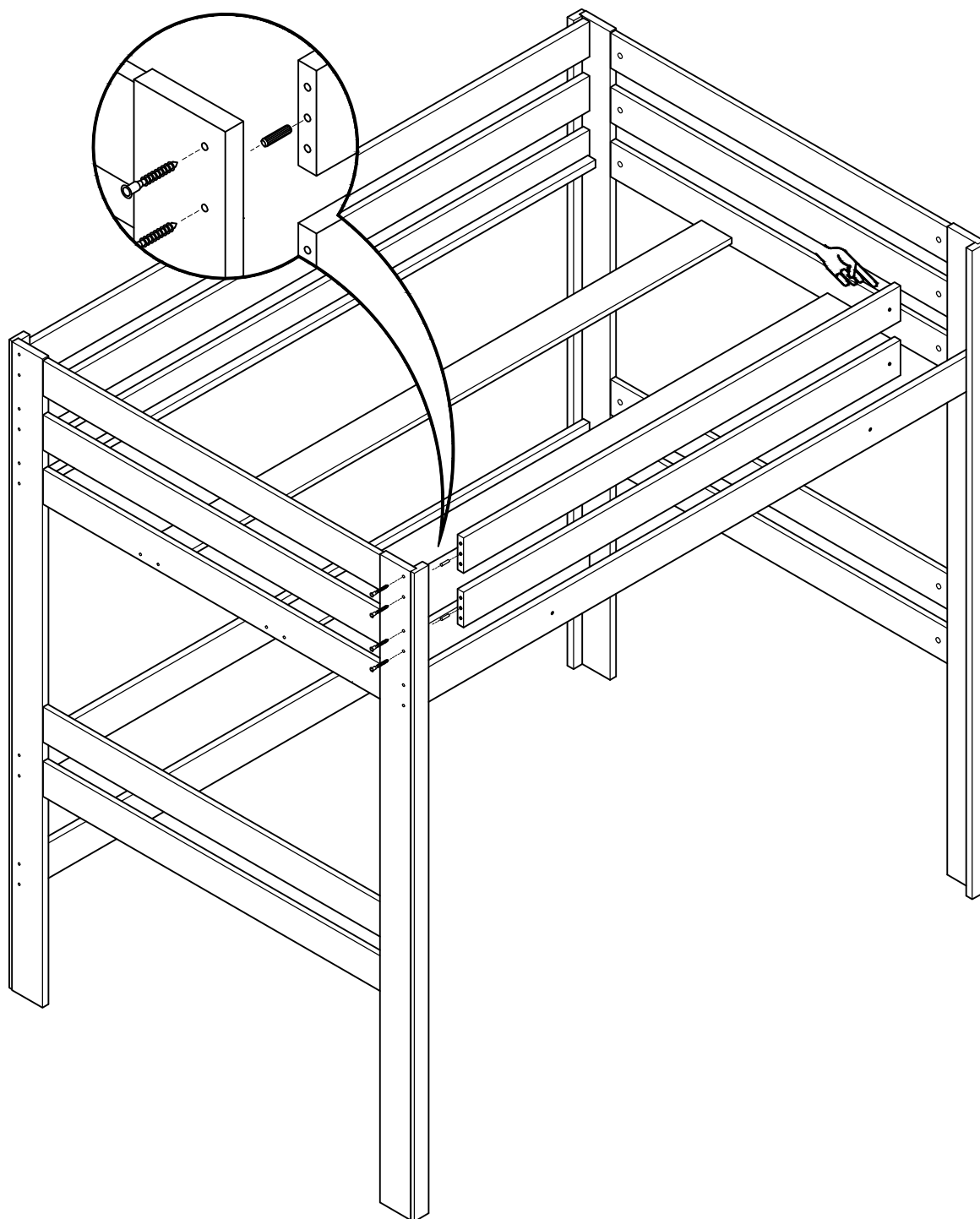
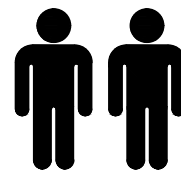

L U F E

13  x 2  x 4



L U F E

14  x 2  x 4

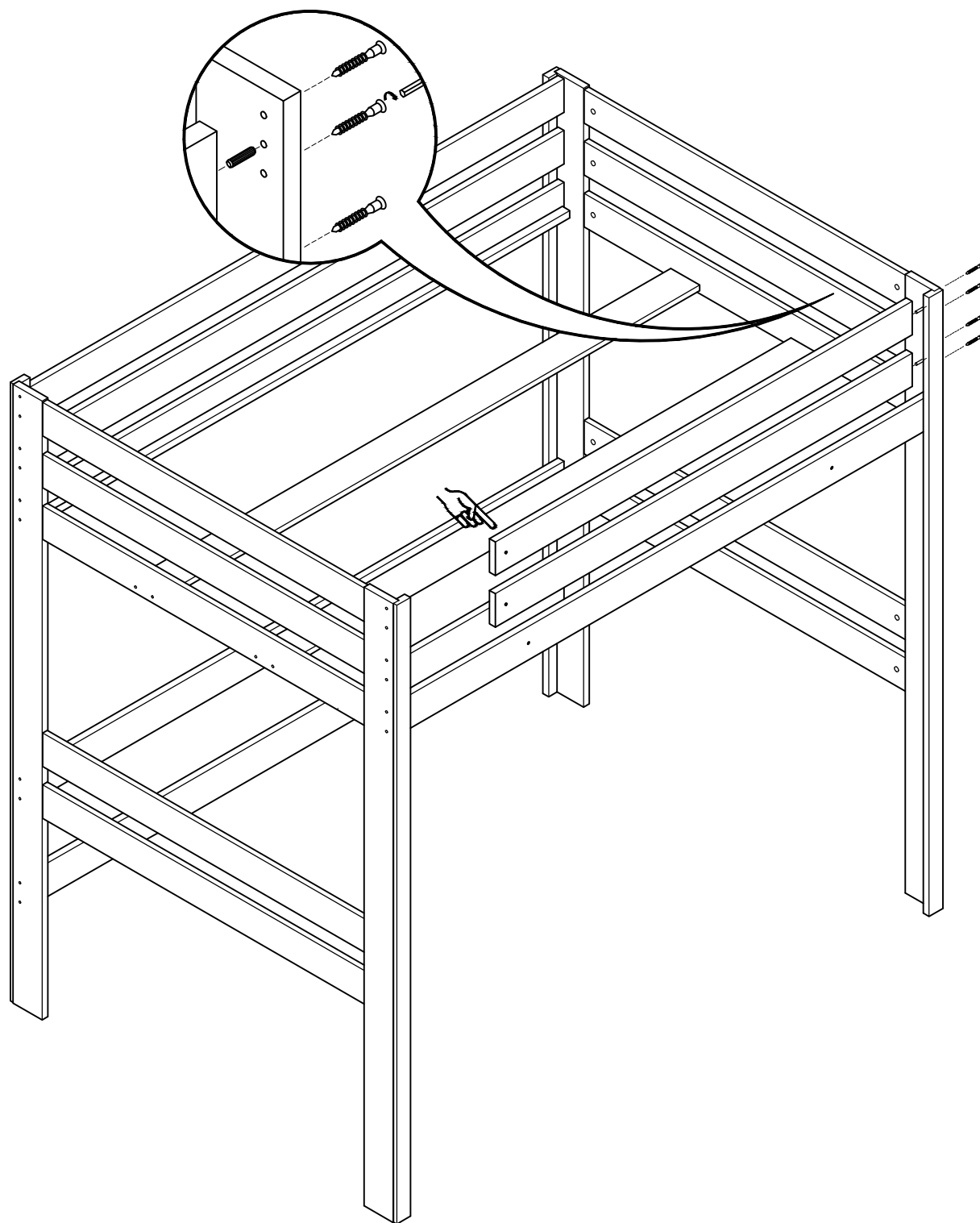
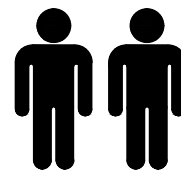

L U F E

15

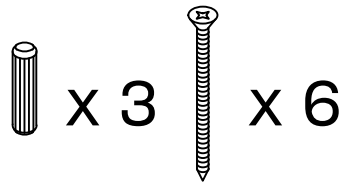

x 3

x 6

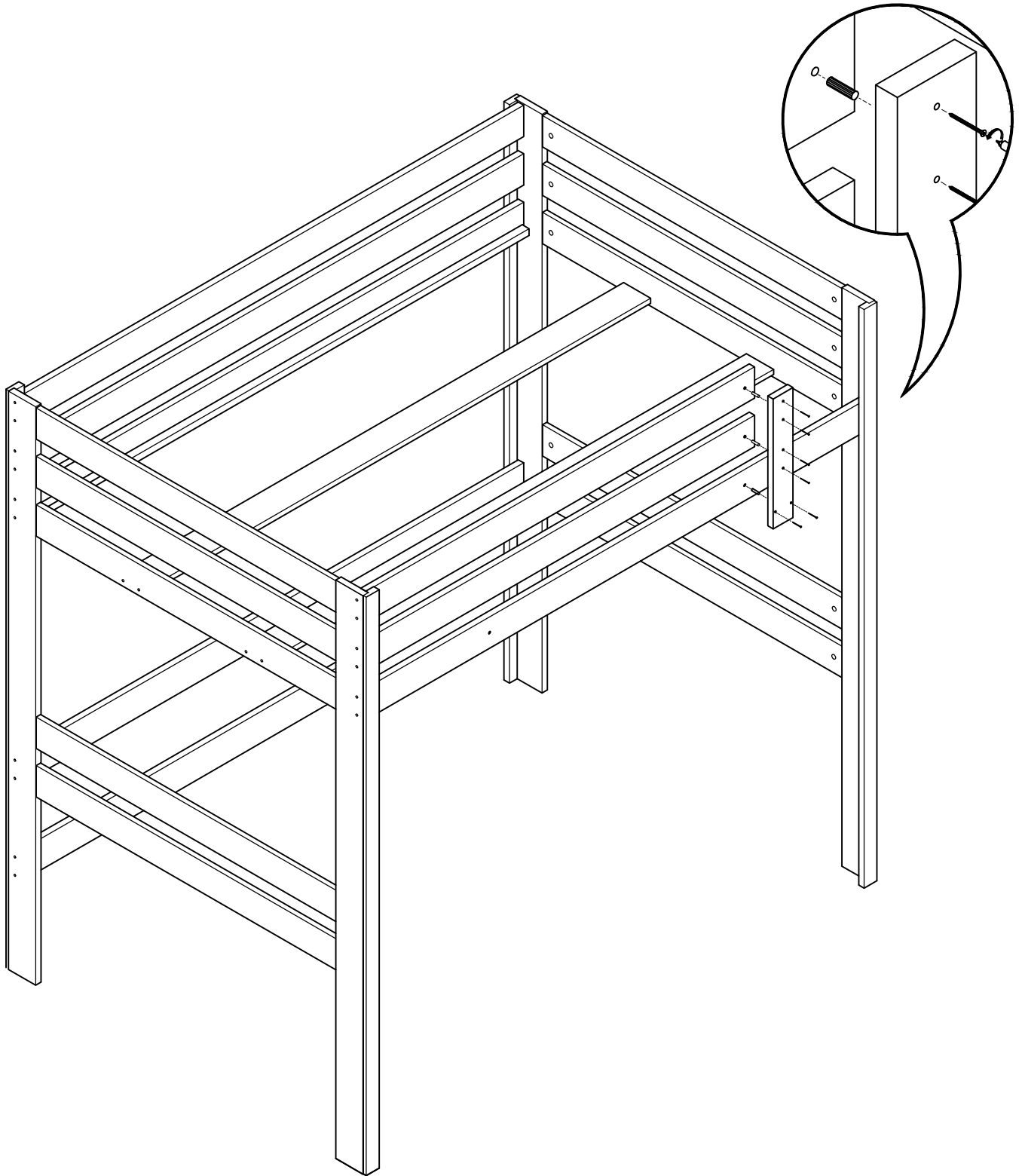
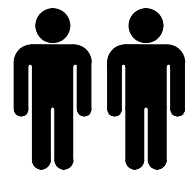

L U F E



16

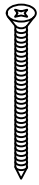

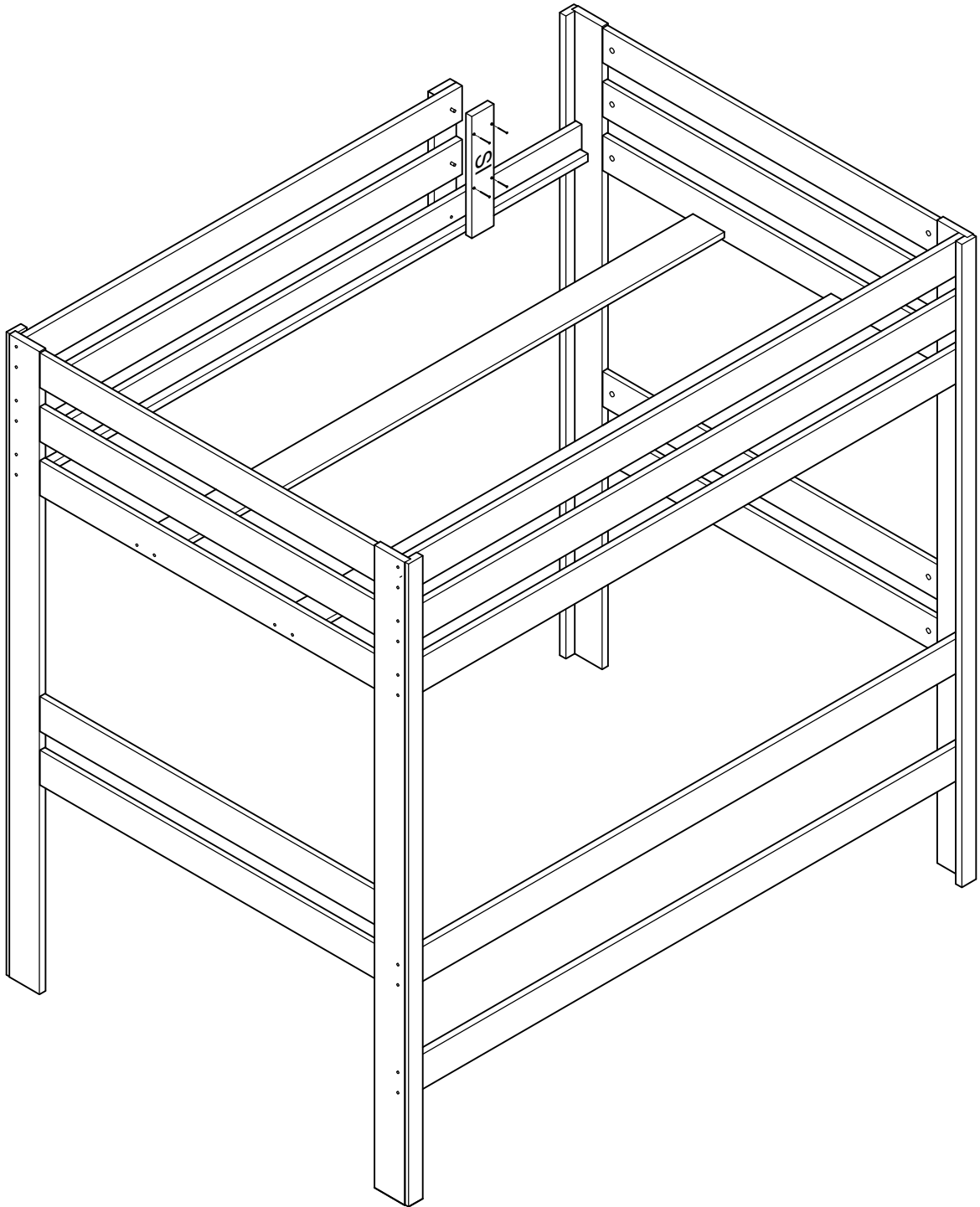
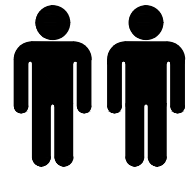

x 4

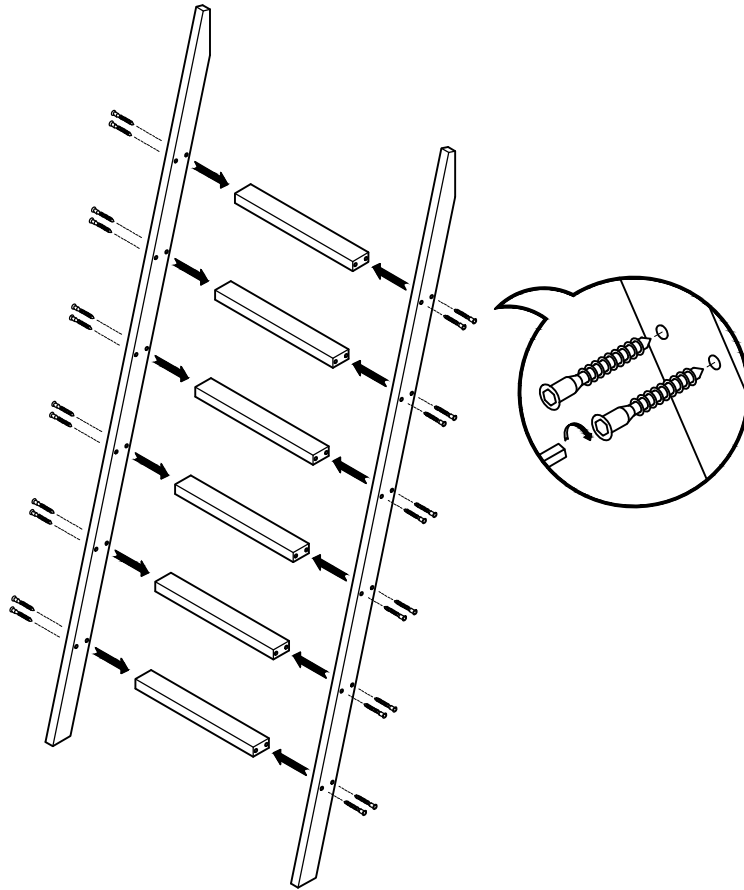

L U F E

17  x 24



18  x 4

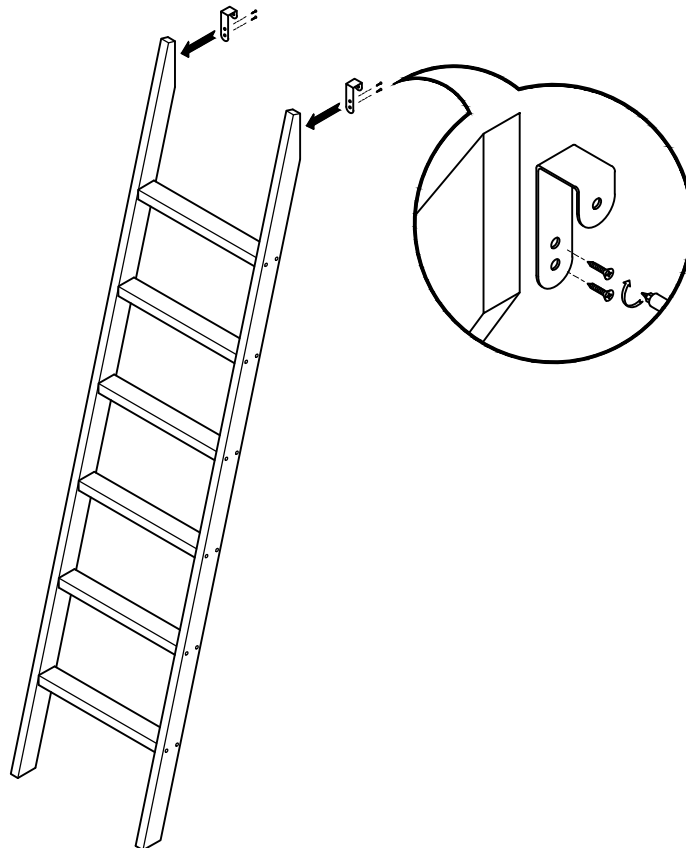

L U F E

19  x 2

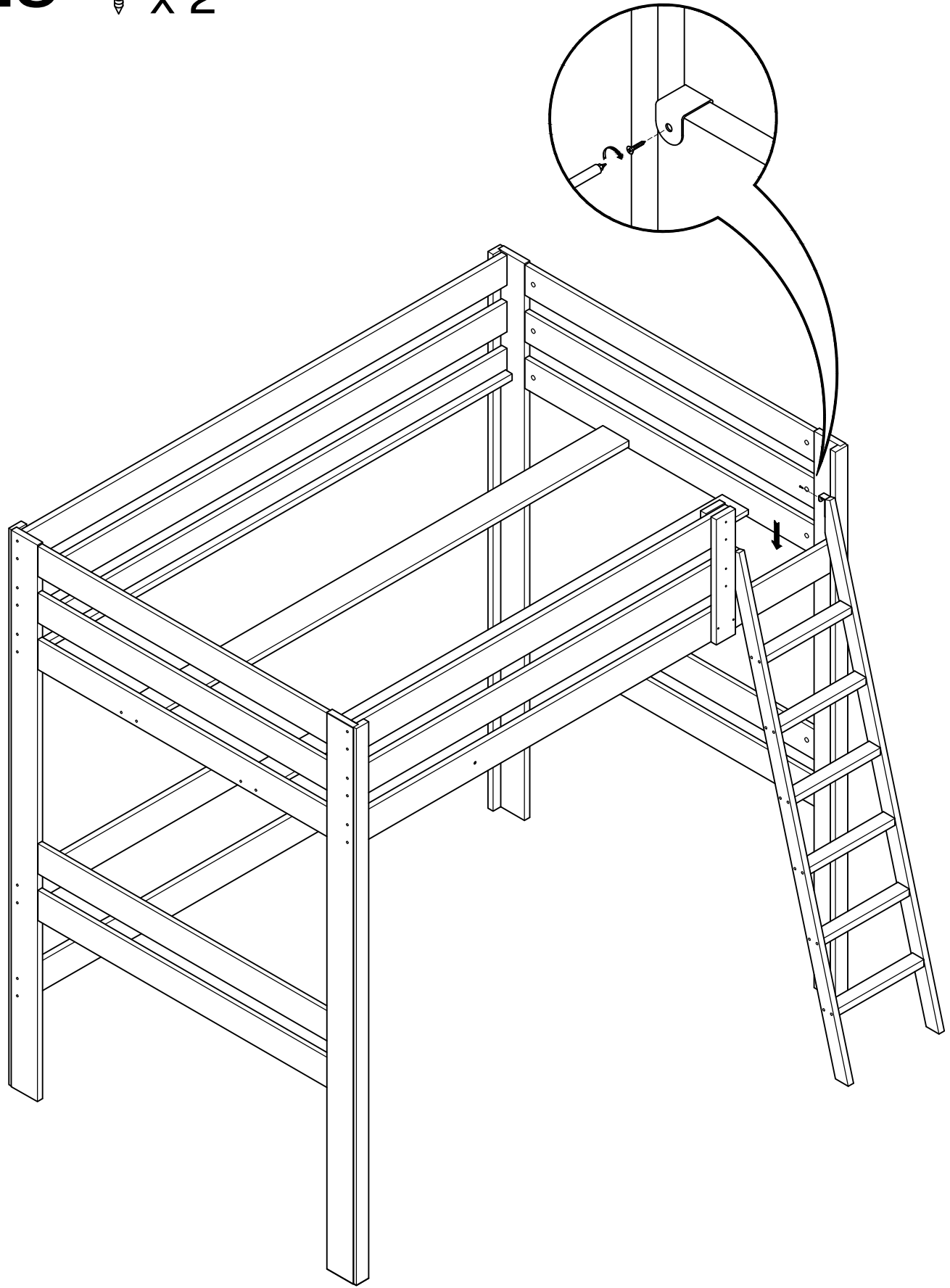

L U F E

20  x 4  x 2

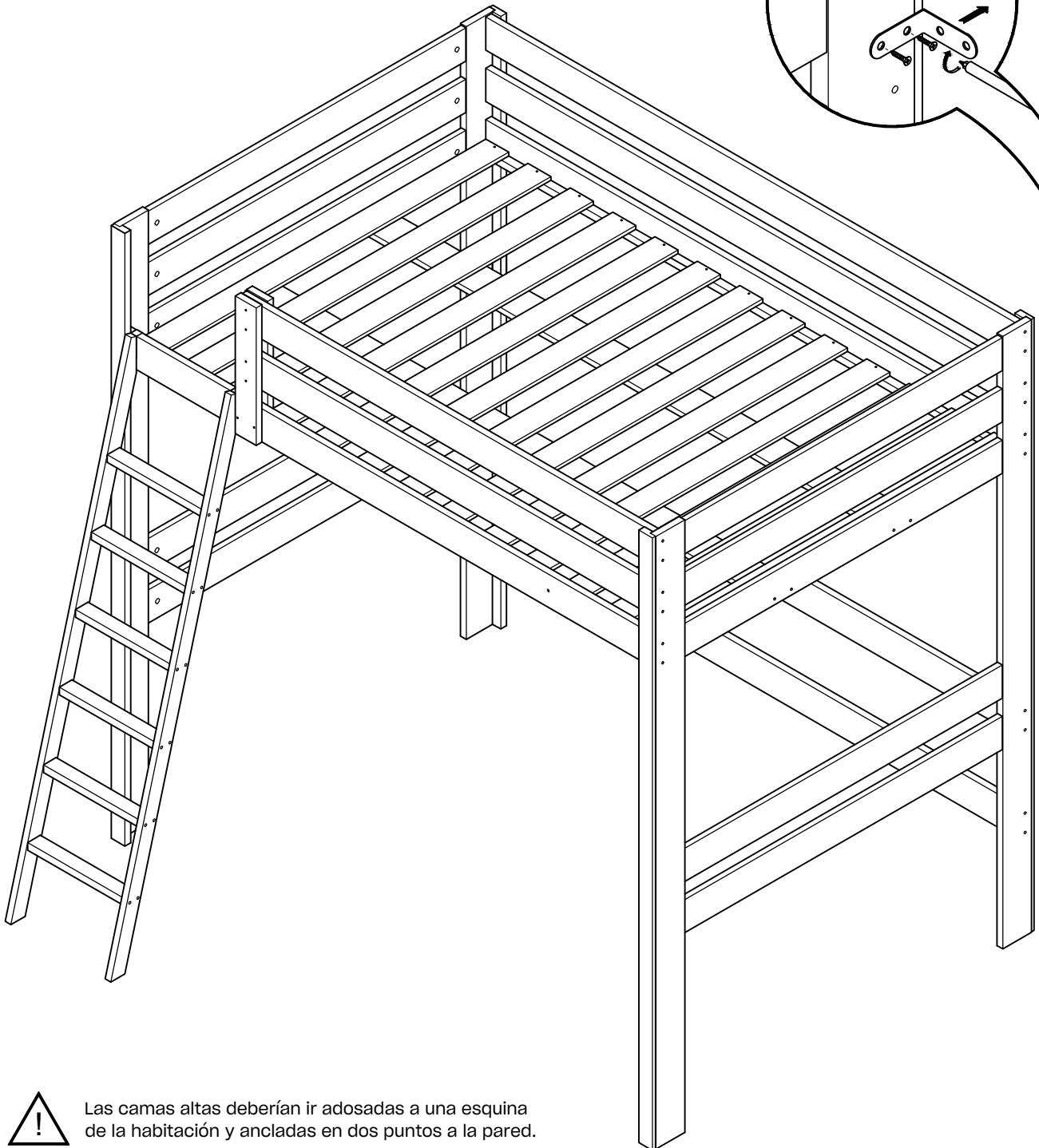
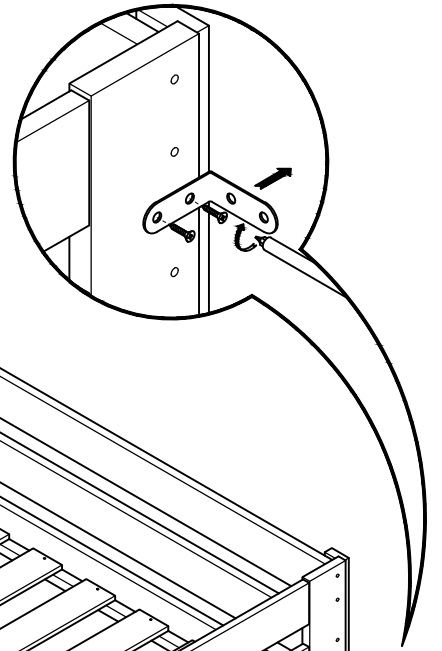

Las camas altas deberían ir adosadas a una esquina de la habitación y ancladas en dos puntos a la pared.

Les lits hauts devraient être fixés dans un coin de la pièce et ancrés au mur en deux points.

As camas altas deveriam ser colocadas num canto do quarto e fixada em dois pontos na parede.

**L U F E**

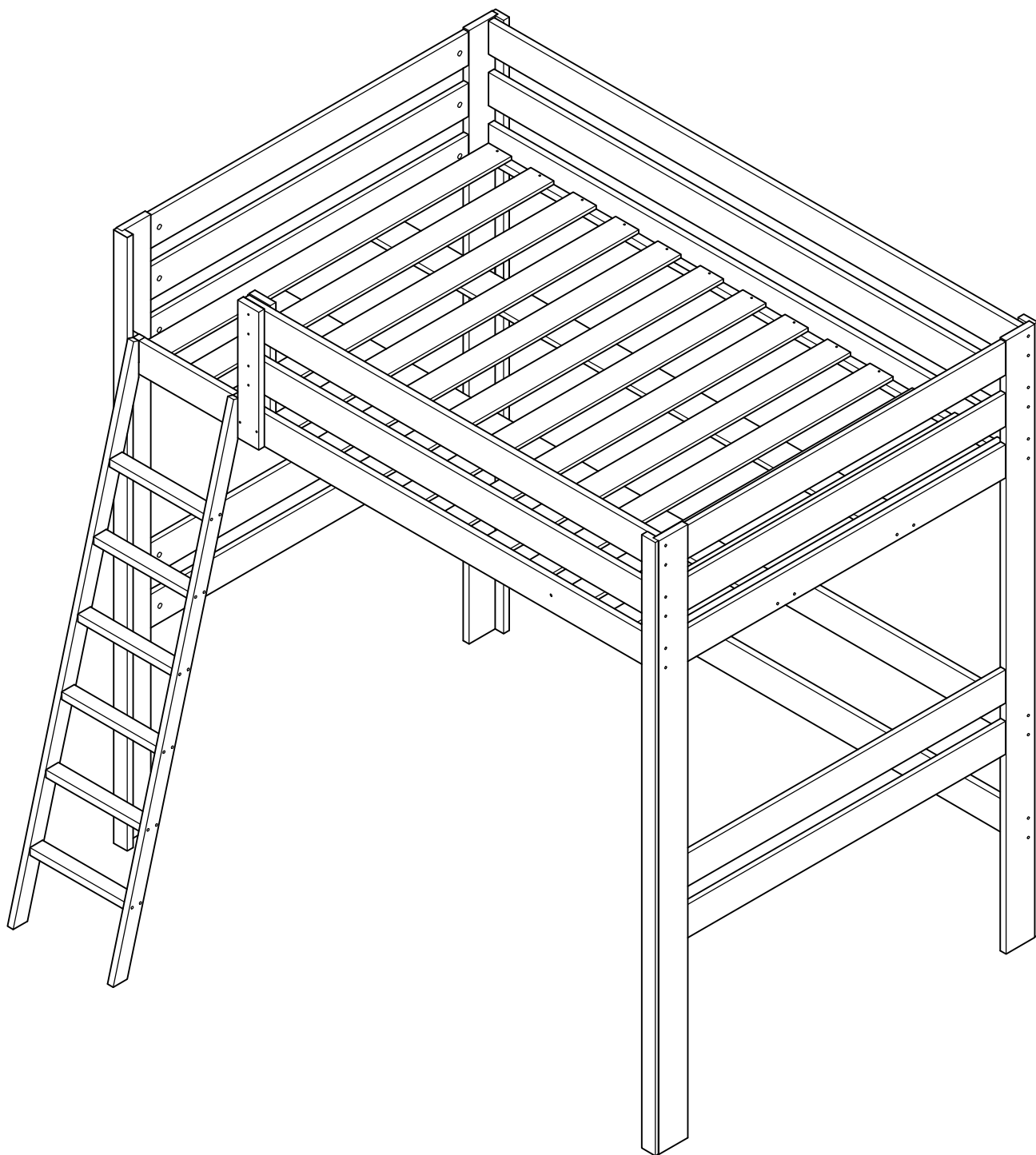

**L U F E**

ESPAÑA  
muebleslufe.com  
@muebleslufe

FRANCE  
meubleslufe.fr  
@lufefrance

PORTUGAL  
moveislufe.pt  
@lufeportugal

---

**L U F E**

TODOLUFE S.L.  
Pol. Ind. Etxezarreta 9  
20749 Aizarnazabal (Gipuzkoa)

(+34) 943 810 795  
info@muebleslufe.com